

CPM-12A

Multifunction Power meter
(คู่มือภาษาไทย)



CPM-12A Manual

Description

เครื่องวัดพลังงานมัลติฟังก์ซ์ CPM-12A ให้ความแม่นยำสูงแบบเฟสเดียวและสามเฟสและ การแสดงพลังงาน, การสะสมพลังงาน, การวิเคราะห์คุณภาพไฟฟ้าและการสื่อสารข้อมูล ฮาร์ดแวร์สามารถเป็นพอร์ตสื่อสาร RS485 Modbus ได้

Panel Description

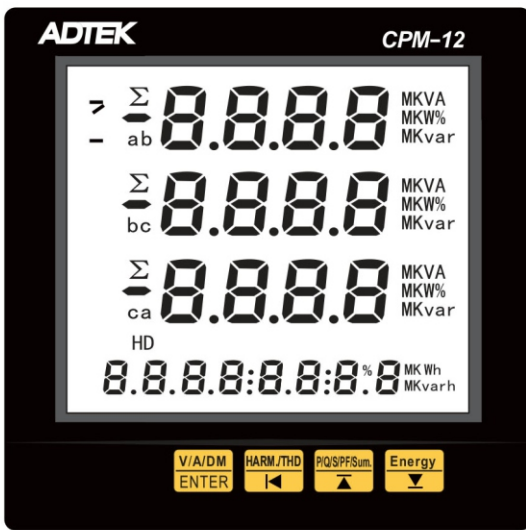

Display	Description
Three line of 8 digits in the metering area	Display metering data such as voltage \ current \ power factor \ unbalance \ etc.
MKVA \ MKW \ MKvar \ %	Display metering data unit
a \ b \ c	a, b, c for 3 phase
ab \ bc \ ca	a-b, b-c, c-a for 3 phase line to line
Eight 8	Display energy value
MK Wh \ MK varh	Display energy unit
HD	THD of Voltage / Current
Σ	Summary or Average
\rightrightarrows	Communication indicator icon
-	Wiring changed

V/A/DM ENTER	Enter / Confirm Quickly index: Voltage / Current
HARM./THD ←	Shift input position / Press 2sec back to previous menu Quickly index: THD
P/Q/S/PF/Sum ↑	Up / Number increase Quickly index: Power parameters
Energy ↓	Down / Number decrease Quickly index: Energy parameters

Dimensions & Installation

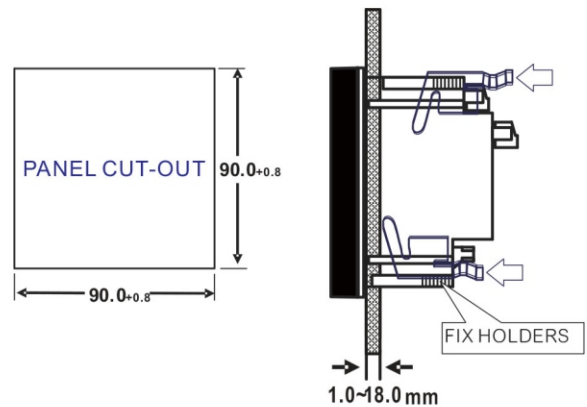
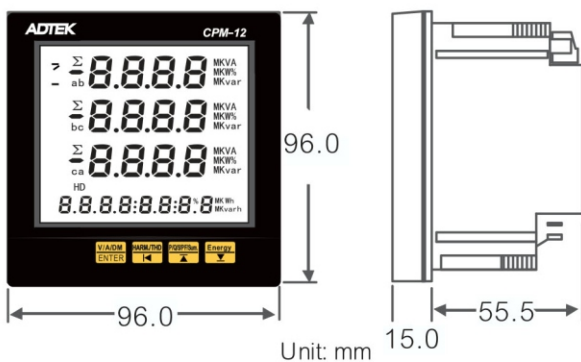

AUX Power

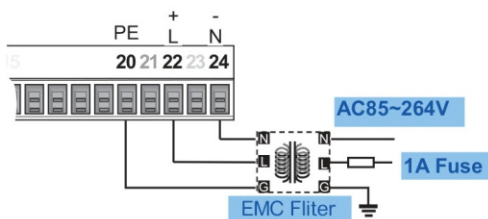

RS485 Communication port

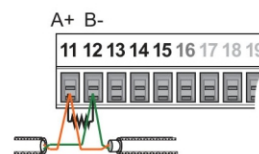

Distance Max. : 1200M
Terminator : 120~300Ω / 0.25W
(Standard: 150Ω)

Operational flow chart

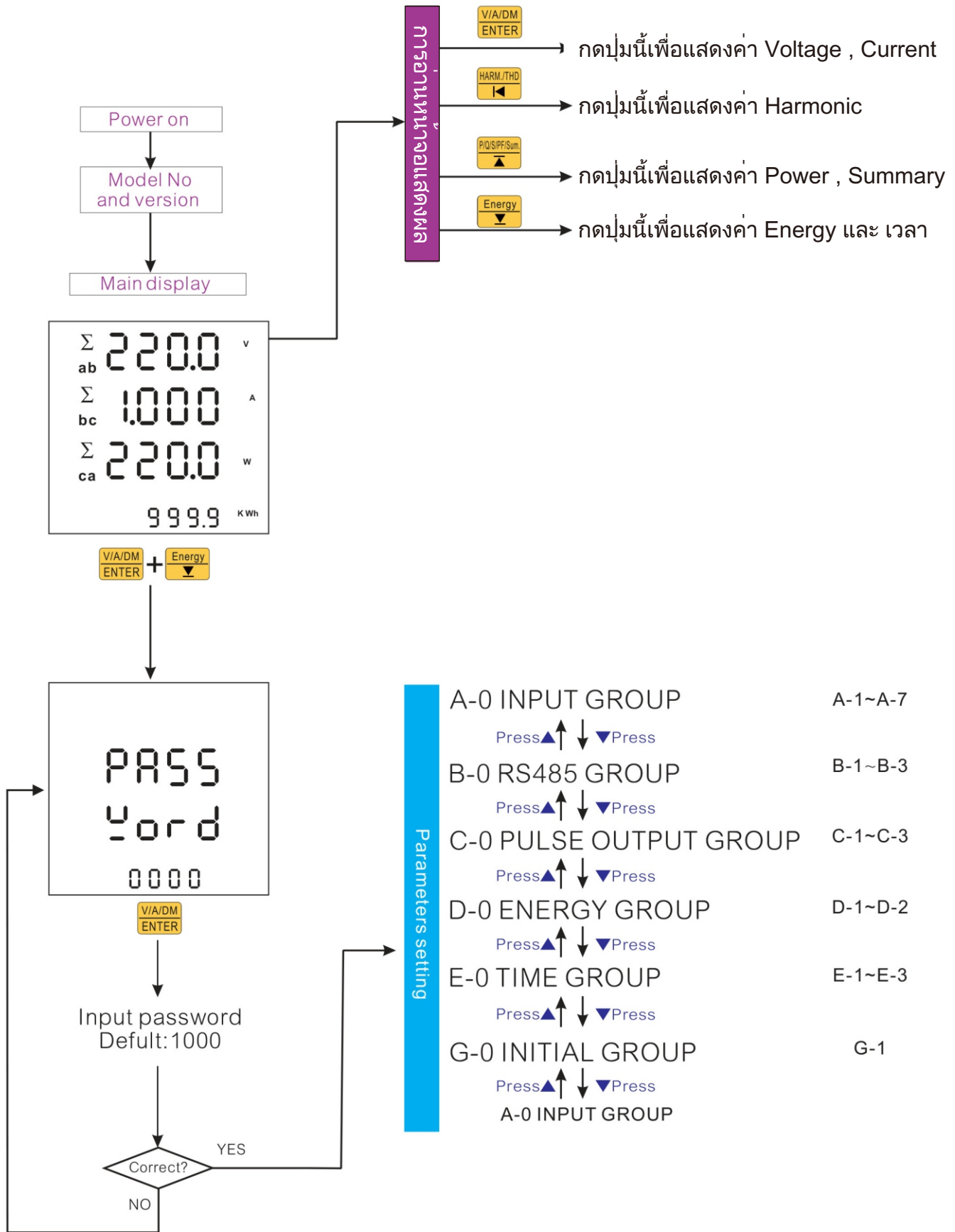

A-0 INPUT GROUP

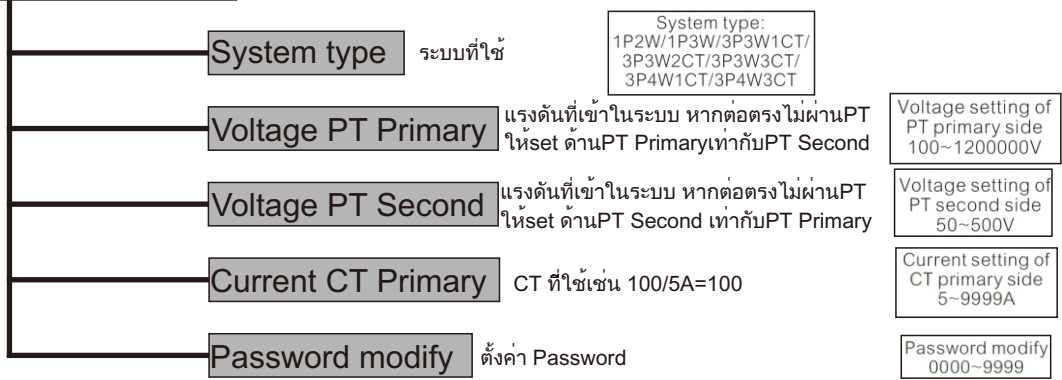

B-0 RS485 GROUP

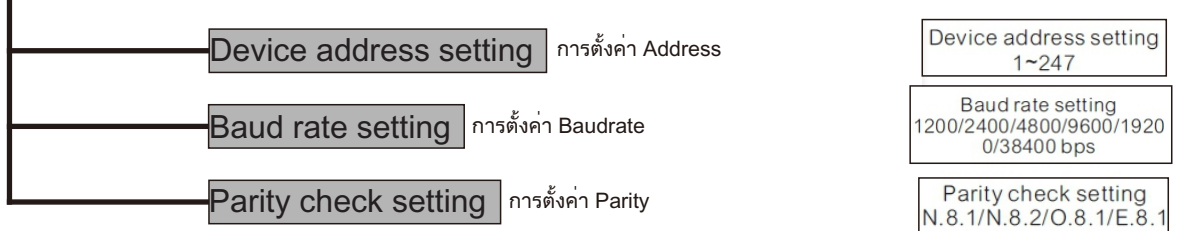

C-0 PULSE OUTPUT

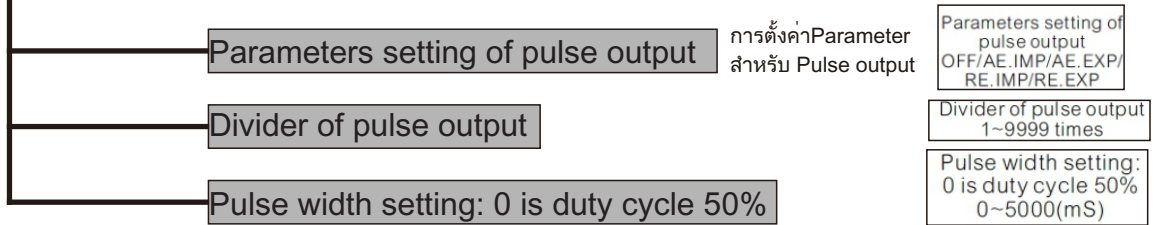

D-0 ENERGY GROUP

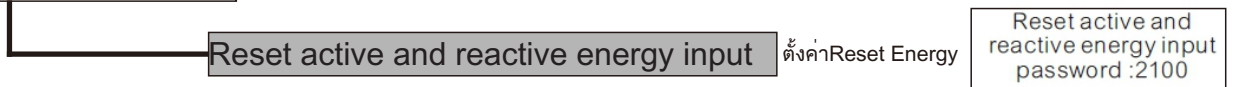

E-0 TIME GROUP

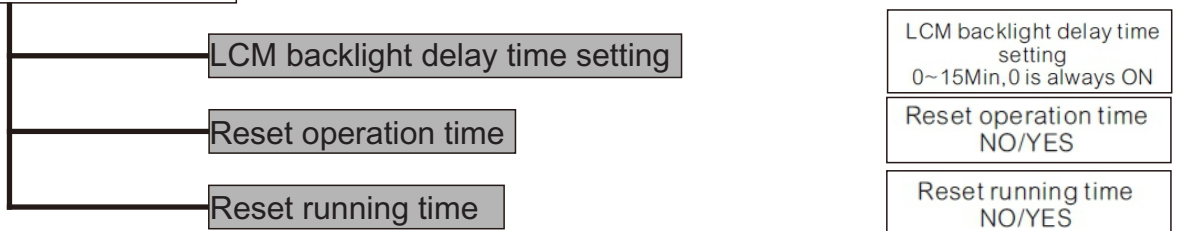

G-0 INITIAL GROUP



การตั้งค่า Parameters

V/A/DM
ENTER : กดในการตั้งค่าหรือยืนยันการตั้งค่า

HARM/THD
◀ : กด 2 วินาทีเพื่อกลับไปยังเมนูหรือหน้าจอหลักก่อนหน้า

กด **V/A/DM**
ENTER + **Energy**

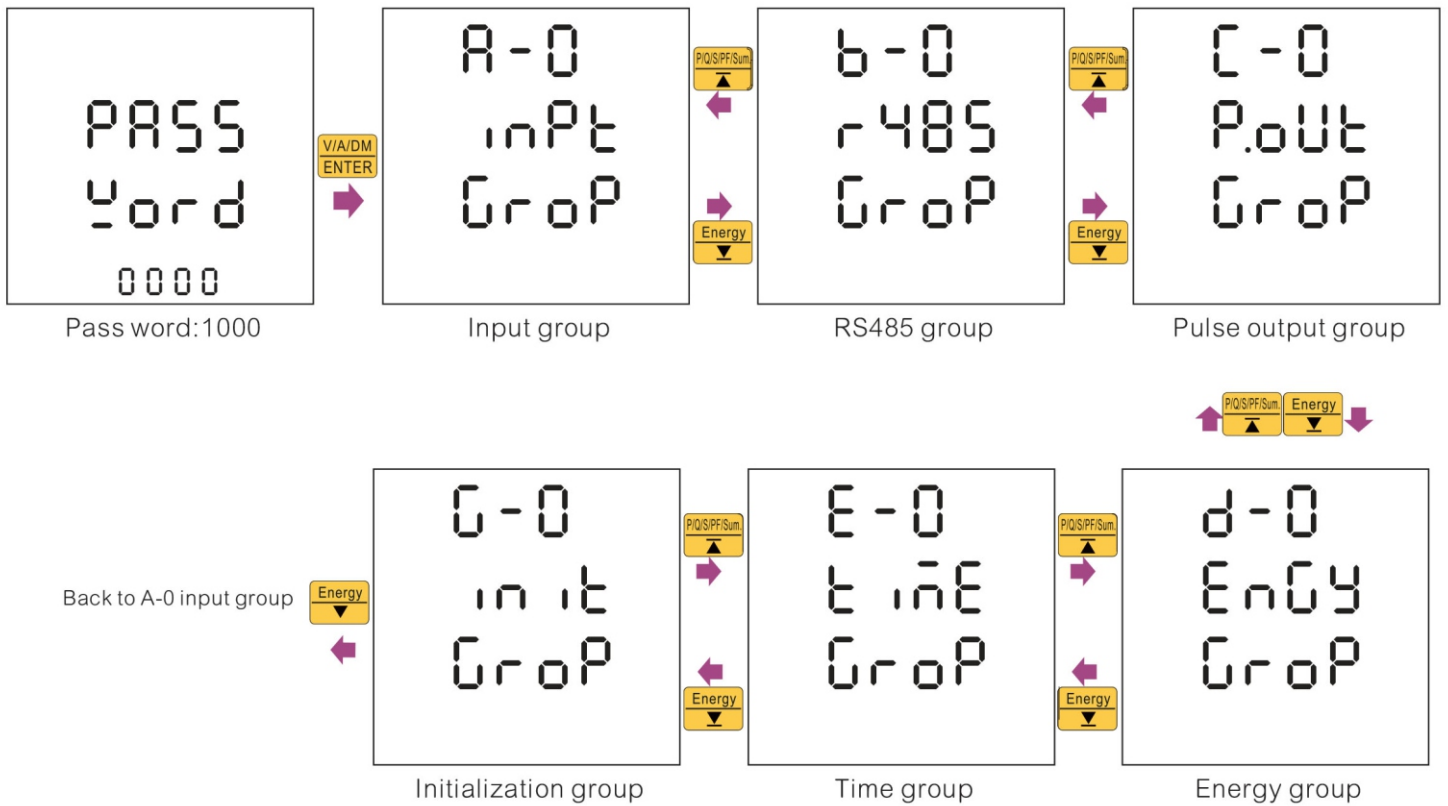

Input Group

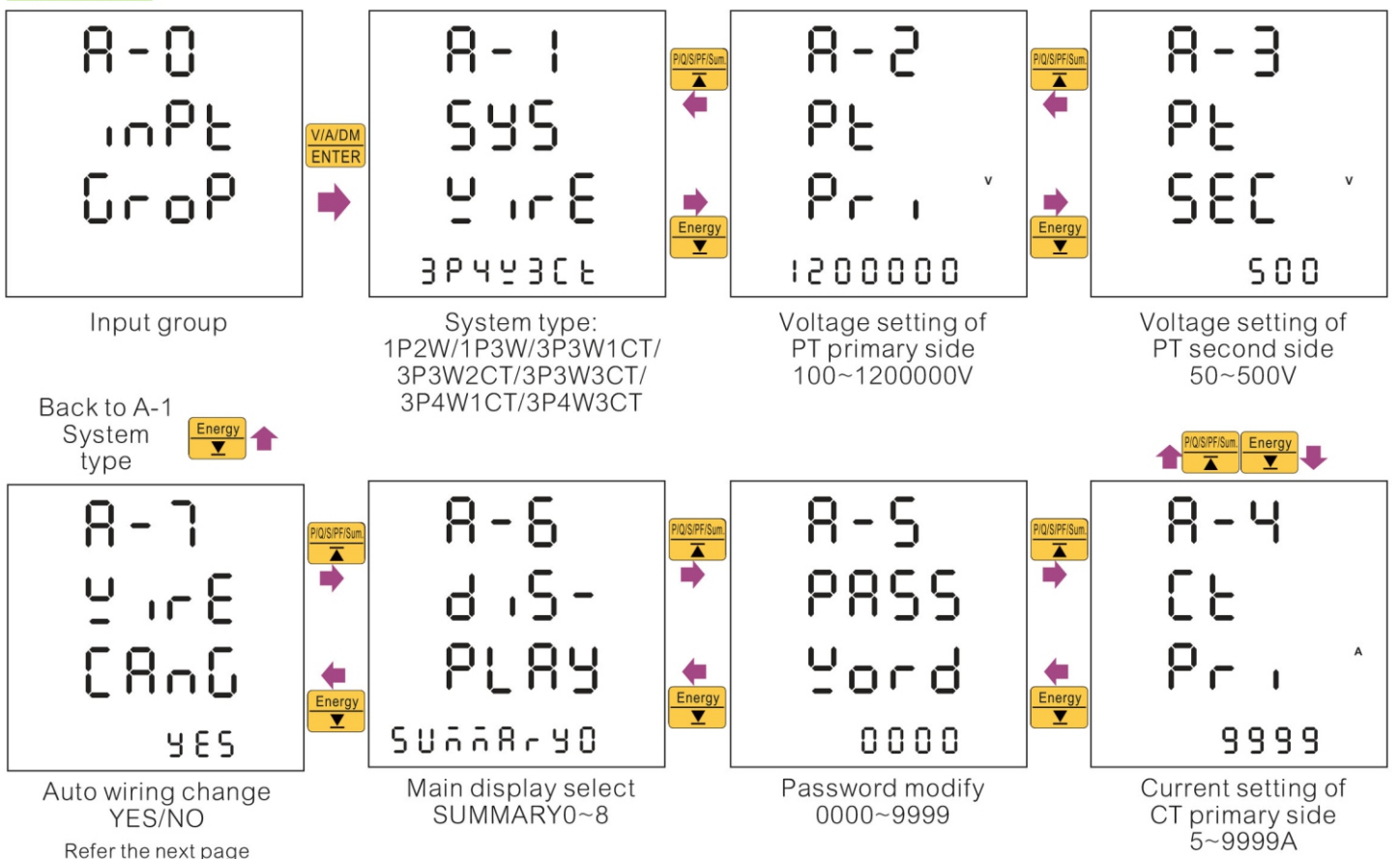

RS485 Group

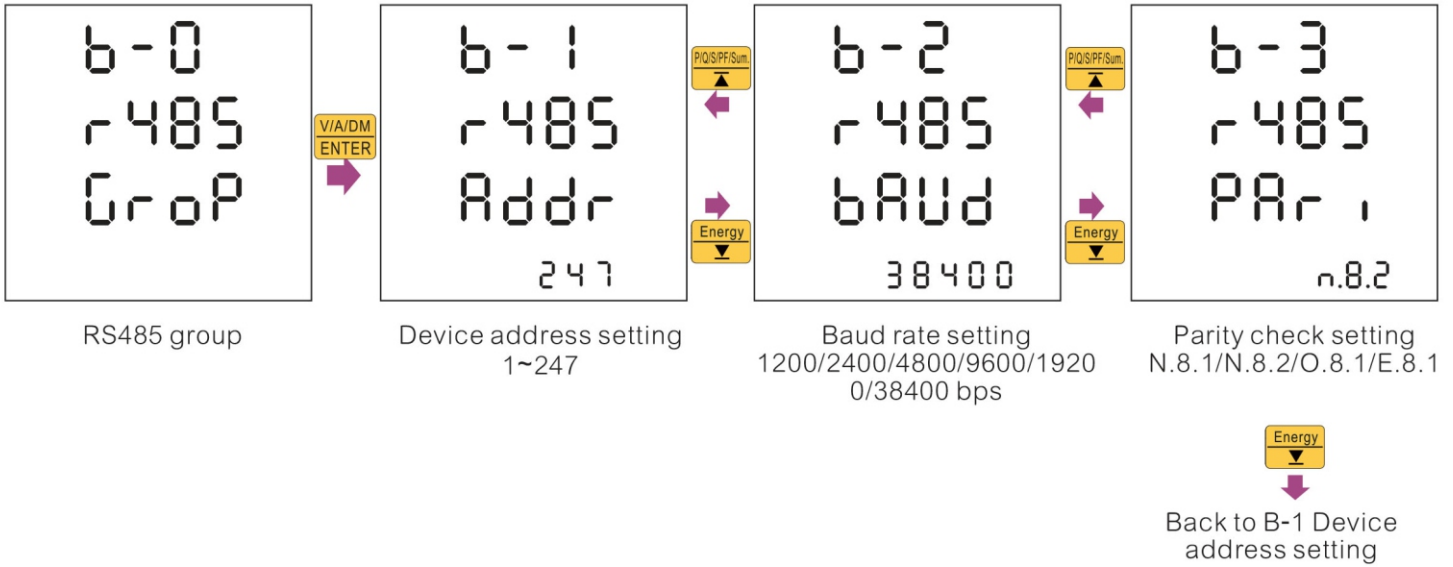

Pulse Output Group

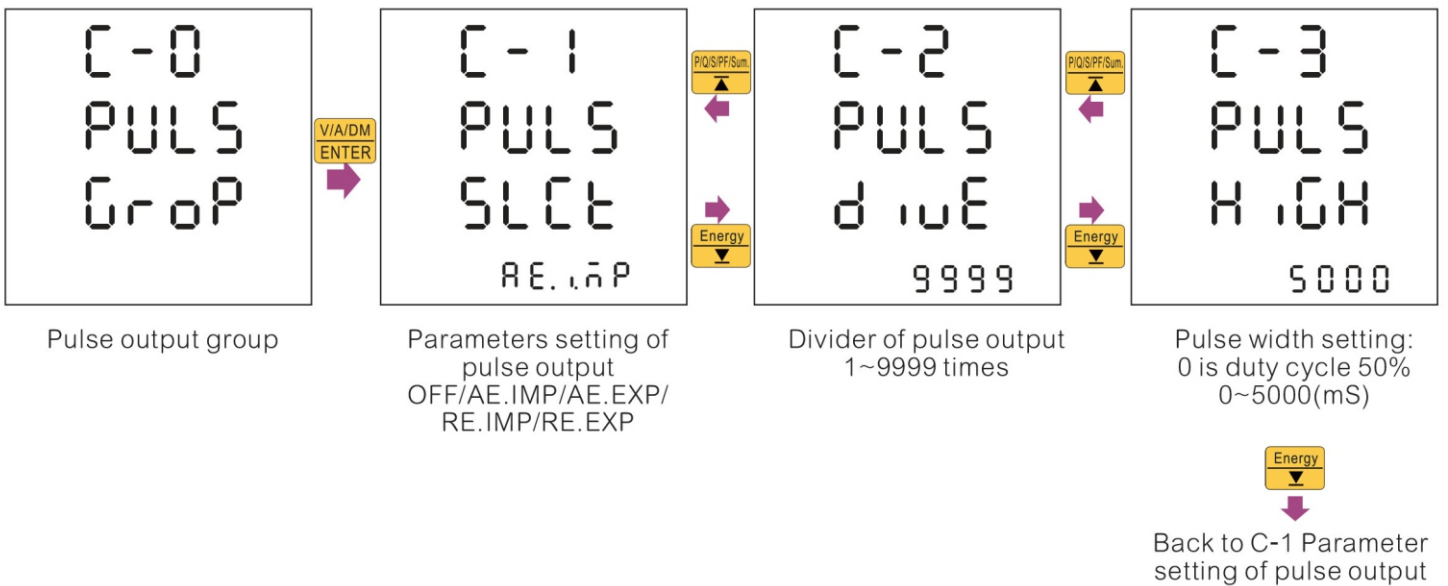

Energy Group

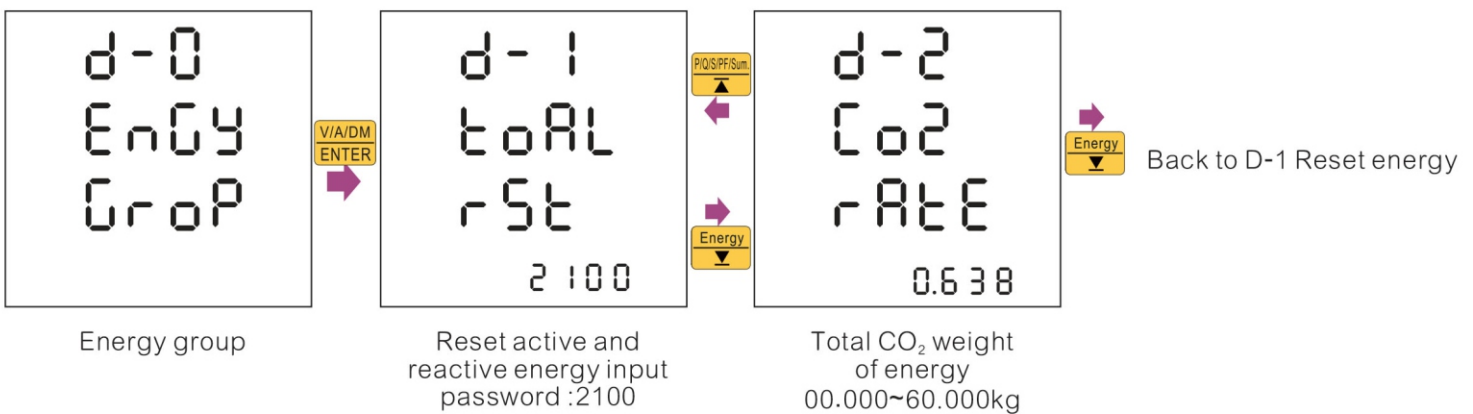

Time Group

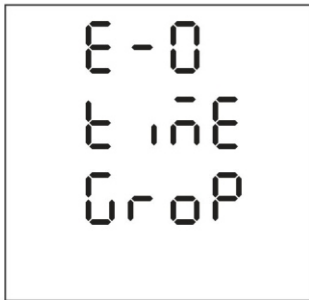

Time group

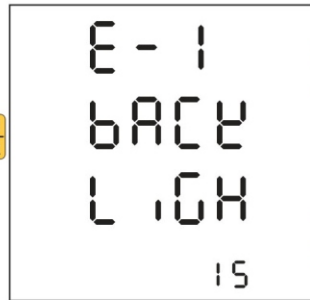

LCM backlight delay time setting
0~15Min, 0 is always ON



Reset operation time
NO/YES



Reset running time
NO/YES



Back to E-1 backlight delay time setting

Initial Group

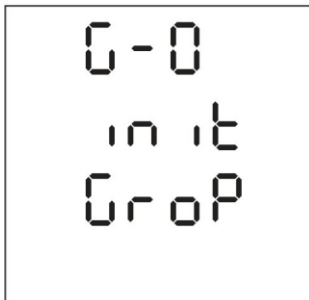

Initialization Group

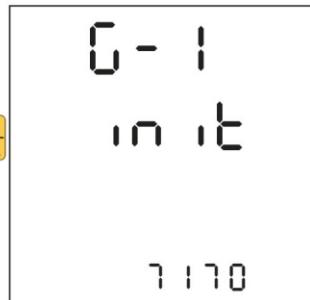

Input password:
7170

ติดต่อบริษัทฯ

หากพบข้อสงสัยในการใช้งานผลิตภัณฑ์ของทางบริษัทฯ กรุณาติดต่อ

CALL SERVICE CENTER (Mon - Fri ; 8:30 A.M. - 17:00 P.M.)

Tel : 02-523-9453 to 4

Contact Us

HOTLINE SERVICE (24 Hrs)

Mr. Suttipong (Tel : 092-280-1910)

Mr. Krirk (Tel : 083-439-3388 or 086-511-4991)

Mr. Pichit (Tel : 081-853-3184 or 081-467-3074)



MEASURING AUTOMATION COMPANY, LTD.
801/121 moo8, Phaholyothin Rd., Kookod, Lamlukka, Pathumthani 12130
Tel : 662-523-9453 to 4 , Fax : 662-523-9440, 662-523-9440
E-mail Contact : sales@mac-me.com , www.mac-me.com