

POWER FACTOR CONTROLLER RG3-T

1. INTRODUCTION

1.1 About User Manual

This User Manual is for quick installation of RG3-T. Before installation and operation please, read this section very carefully.

1.2 Precautions for Safe Use and Installation

- Maintenance, installation and operation of RG3-T must be performed only by the qualified electricians.
- Disconnect power before working on the equipment.
- Do not operate RG3-T undervoltage.
- Do not open the RG3-T's housing. There are no user servicable parts inside it.
- RG3-T is connected to the network by means of a current transformer. Do not disconnect the current transformer terminals, if you disconnect them, be sure to short circuit or connect them to another parallel load having sufficiently low impedance. In case of failure dangerously high voltage at the secondary side of current transformer may cause an electric shock.
- Do not use this product for any other purpose than its original task.
- When the device is connected to the network, do not remove the front panel.
- Do not clean the device with solvent or the like. Only clean with a dried cloth.
- Verify correct terminal connections when wiring.
- Electrical equipment should be serviced only by your competent seller.
- Only for rack panel mounting.
- No responsibility is assured by **the manufacturer** or any of its subsidiaries for any consequences rising out of the use of this material.

2. GENERAL

Power Factor Controllers are used for measurement and control of power factor control units for central reactive power compensation. The Power Factor measured by RG3-T is compared with the set values and in order to provide necessary compensation, Power Factor Controller switches capacitor banks ON and OFF automatically. RG3-T is 3-phase microcontroller relay, designed for above application in 144x144 case for flush mounting with rear plug-in connectors. RG3-T calculates the average Power Factor of 3-phase systems as described in section 6.2. In addition, RG3-T displays the following values.

- Power factor (phase by phase and average of 3 phase)
- Cos ϕ (phase by phase and average of 3 phase)
- Phase-Neutral & Phase-Phase voltages (VAC)
- 3-Phase current (I)
- 3-Phase active power (W)
- Total active power (IW)
- 3-Phase reactive power (VAr)
- Total reactive power (IVAr)
- 3-Phase apparent power (VA)
- Total apparent power (IVA)

3. FRONT PANEL SPECIFICATIONS

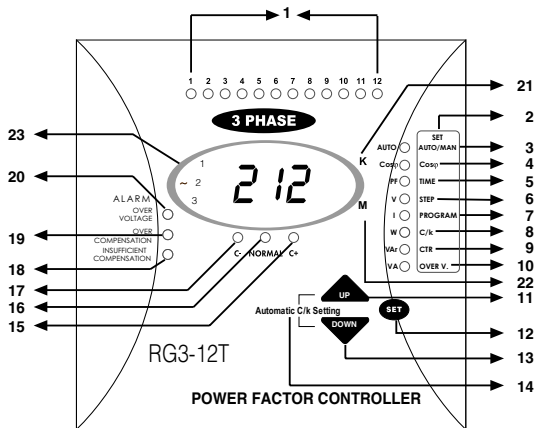

On the front panel of RG3-T, there are warning lights, display and 3 buttons for settings.

3.1 Buttons and Lights

- 1, 2, ..., 12 : Shows the status of each capacitor steps.
- SET Menu : Displays the Menu options.
- AUTO/MAN Light : If it is continuously ON, RG3-T is in Automatic Mode. It blinks RG3-T is in Manual Mode. Push SET 3 seconds to enter the Menu and change operating Mode. (Refer to: 5.1)
- Cos ϕ Light : Push SET 3 seconds, select Cos ϕ light, to adjust Cos ϕ manually. (Refer to: 5.3). In Automatic Mode, it displays the Cos ϕ value. (Refer to: 5.10)
- TIME/PF Light : Push SET 3 seconds, select TIME/PF light, to adjust step time. (Refer to: 5.4) In Automatic Mode, it displays the system's Power Factor. (Refer to: 5.11)
- STEP/V Light : Push SET 3 seconds, select STEP/V light to adjust step number. (Refer

to: 5.5)

In Automatic Mode, it displays the phase's voltage value. (Refer to: 5.12)

- PROGRAM/I Light : Push SET 3 seconds, select PROGRAM/I light to adjust power sequence program. (Refer to: 5.6) In Automatic Mode, it displays the phase's current value. (Refer to: 5.12)
- C/k - W Light : Push SET 3 seconds, select C/k-W light to adjust C/k value manually. (Refer to: 5.7) In Automatic Mode, it displays the phase's active power value. (Refer to: 5.13)
- CTR - VAr Light : Push SET 3 seconds, select CTR-VAr light to adjust current transformer ratio. (Refer to: 5.8) In Automatic Mode, it displays the phase's reactive power value. (Refer to: 5.14)
- Over V. / VA Light : Push SET 3 seconds, select Over V/VA light to adjust protection of capacitor steps against over voltage function. (Refer to: 5.9) In Automatic Mode, it displays the phase's apparent power value. (Refer to: 5.15)
- UP : To scroll up in the Menu.
- SET : Enter button for different settings.
- DOWN Button : To scroll down in the Menu.
- Automatic C/k Setting : To adjust C/k value automatically, push UP / DOWN buttons together. (Refer to: 5.2)
- C+ Light : ON if RG3-T switches capacitor steps on.
- NORMAL Light : ON if the targeted compensation is achieved.
- C- Light : ON if RG3-T switches capacitor steps off.
- Insufficient Compensation Light : ON if insufficient compensation occurs. (Refer to: 6.1.2)
- Over Compensation Light : ON if over compensation occurs. (Refer to: 6.1.3)
- Over Voltage Light : ON if over voltage occurs. (Refer to: 6.1.1)
- K (Kilo) Light : If ON displayed value must be multiplied by 1000.
- M (Mega) Light : When this light is ON multiply display value by 10^6 .
- 1-12 Lights : Displays the related phase. (1=L1, 2=L2, 3=L3)

4. CONNECTION DIAGRAM

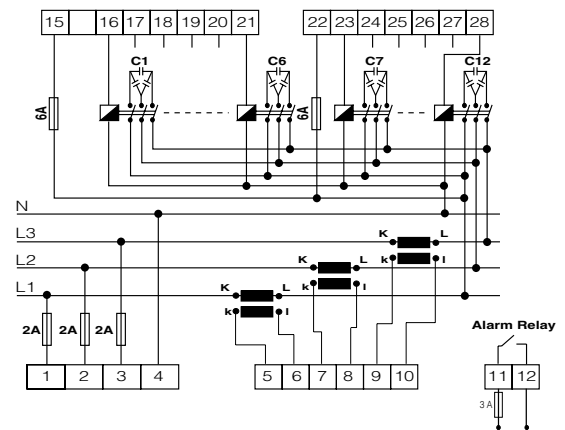

Warnings:

- If the point at the right most digit of the display is blinking quickly when the Active Power (W) is displayed (Refer to: 5.13), please change the order of current terminals (k-l) of related phase.
- Connection of circuit breaker is highly recommended between the network and RG3-T.
- Circuit breaker must be in close proximity to the device.
- Circuit breaker must be marked as the disconnecting device for the equipment.
- All the used fuses must be FF type and the current values of the fuses must be 2A, 3A and 6A.

5. CONTROLS AND MENU OPERATIONS

All settings are made through the Menu. The set values, except operating mode are kept in memory even if the device is switched off. When it is switched on, it starts compensation with the values stored in the memory in Automatic Operating Mode. After entering Menu, if you don't make any adjustments during 20 seconds, RG3-T operates with the previously stored values. To quit Menu, UP-DOWN buttons are pressed until the ESC symbol is displayed and then SET button is pressed.

POWER FACTOR CONTROLLER RG3-T

5.1 Selection of Operating Mode(Automatic / Manual Mode)

- 1) Automatic Mode: The capacitor steps are controlled by RG3-T, automatically.
 - 2) Manual Mode: The capacitor steps are switched on/off, manually.
- Mode selection is done as followed.

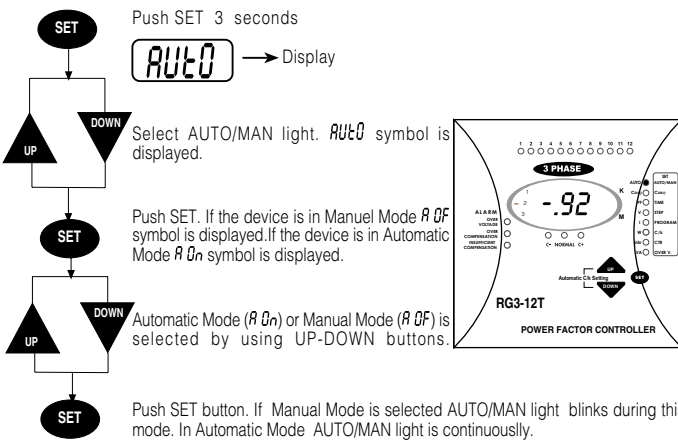

5.1.1 Switching of the Capacitor Steps Manually

When RG3-T is in Manual Mode, capacitors are connected by pressing UP button. Each time UP button is pressed C+ light is ON, and one step is connected accordingly; NORMAL light will be ON after the connection. Repeat this for connecting more steps.

Capacitors are disconnected by pressing DOWN button. Each time UP button is pressed C- light is ON, and one step is disconnected after a delay; NORMAL light will be ON after the disconnection of the step. Repeat this for connecting more steps.

5.2 Automatic C/k Adjustment



5.3 Cosφ Adjustment

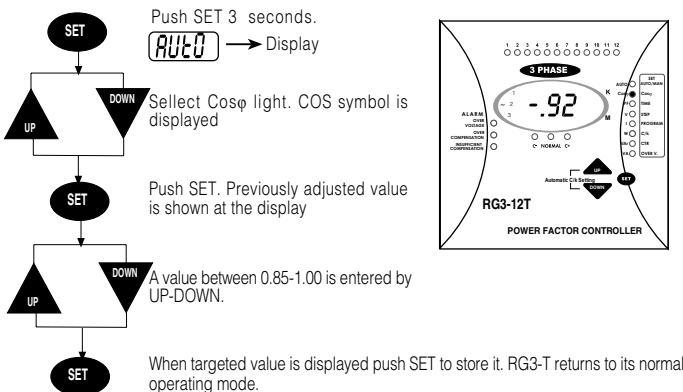

5.4 Step Time Adjustment

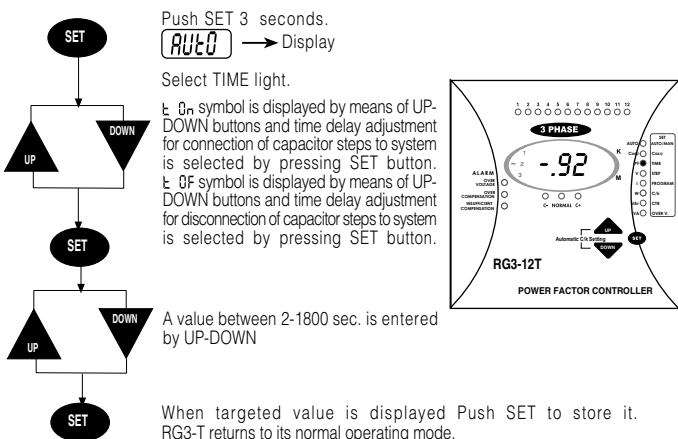

5.5 Step Number Selection

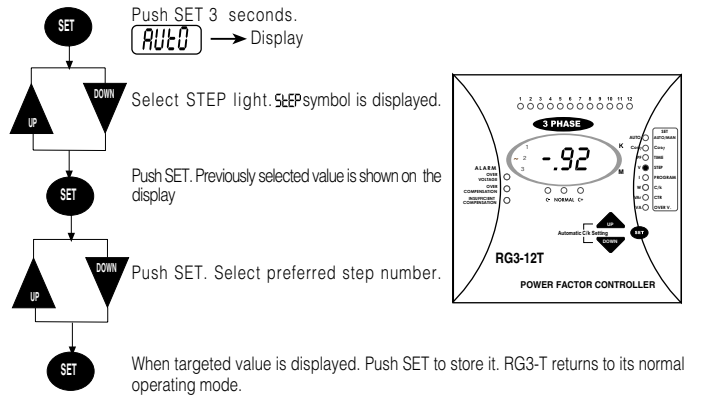

5.6 Switching Program Selection

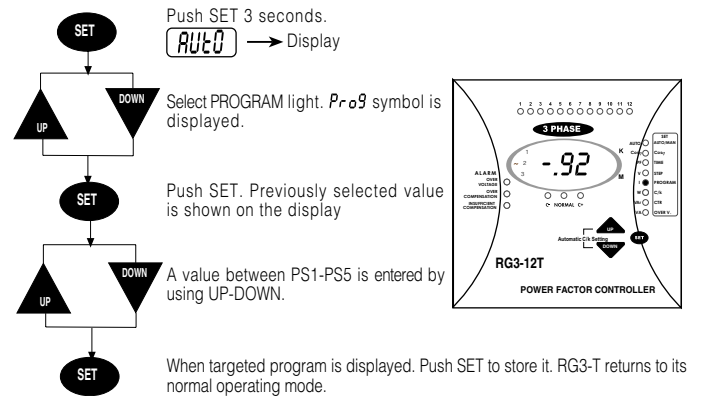

5.7 Selection of C/k Value by the User

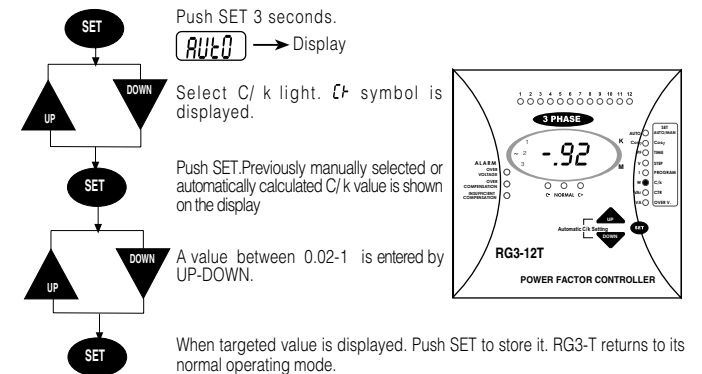

5.8 Selection of Current Transformer Primary Value

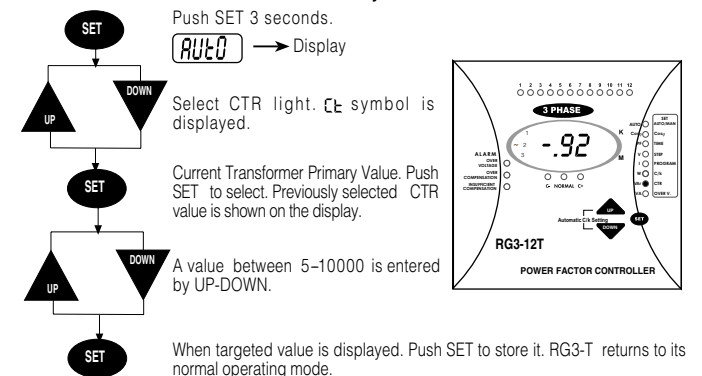

5.9 Protection of Capacitor Steps Against Over Voltage

This is a selectable function, either OFF (Over Voltage Protection Off) or an Over Voltage value between 240-275V can be selected.

If "Over Voltage" occurs when Over Voltage Value is selected (between 240-275V), then all the capacitor steps switch off, OVER VOLTAGE LED turns on and alarm relay activates. And if RG3-T is on Manual Mode, it switches to Automatic Mode.

POWER FACTOR CONTROLLER RG3-T

Function setting is as followed:

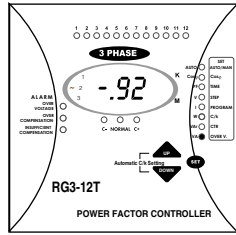
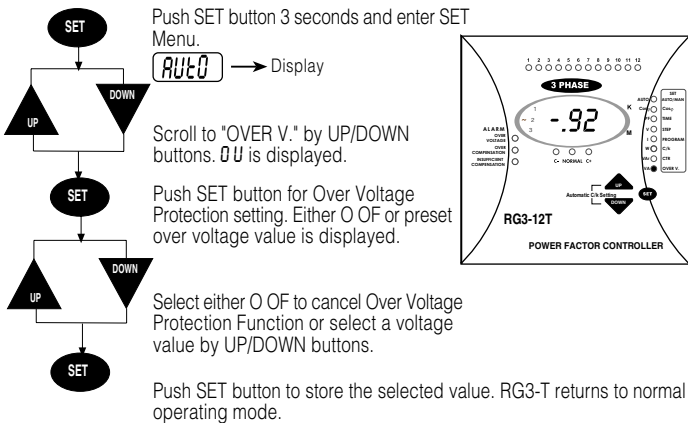

5.10 Display of Cosφ Value

When RG3-T is in Manual Mode, Cosφ value and inductive/capacitive state is always displayed. When Cosφ value is negative, the system is capacitive and if Cosφ value is positive, the system is inductive. In Automatic Operating Mode, system's Cosφ value and ind./cap. state is displayed by selecting the Cosφ light, by means of DOWN button and you can select the measuring phase by pressing UP button. When ~1 2 3 lights are ON, the average Cosφ is displayed.

5.11 Display of Power Factor (PF) Value

When RG3-T is in Automatic Operating Mode (AUTO/MAN light is continuously ON), PF light is selected by means of DOWN button and system's Power Factor value is displayed and you can select the measuring phase by pressing UP button. When ~1 2 3 lights are ON, the average Power factor is displayed. This option is disabled in Manual Operating Mode.

Important Definition: Cosφ is defined Displacement Power Factor and relative to the fundamental harmonic only. PF is defined Total Power Factor and relative to the all harmonics including fundamental harmonic. In a system without harmonics, PF and Cosφ are equal to each other.

Attention: The difference between cosφ and PF values does not mean that voltage harmonics, which results to problems in systems, are high on the network.

5.12 Displaying Voltage and Current RMS Values

When RG3-T is in Automatic Mode (AUTO/MAN light is ON), V light is selected by means of DOWN button, RMS Voltage (V) value of phase L1 is displayed and you can select the measuring phase by pressing UP button. When two of ~1 2 3 lights are ON, phase-phase voltage is displayed that is, if ~1 and ~2 lights are ON, it means L1-L2 phase-phase voltage is displayed.

When RG3-T is in automatic operating (AUTO/MAN light is ON), I light is selected by means of DOWN button, RMS Current (I) value of phase L1 is displayed and you can select the measuring phase by pressing UP button. These options are disabled in Manual Mode.

5.13 Display of Active Power (W) Value

When RG3-T is in Automatic Mode (AUTO/MAN light is ON), W light is selected by means of DOWN button and system's Active Power value of phase L1 is displayed and you can select the measuring phase by pressing UP button. When ~1 2 3 lights are ON, total active power (ΣW) is displayed. This option is disabled in Manual Mode.

Warning: If the point at the right most digit of the display is blinking quickly when the Active Power (W) is displayed, please change the order of current terminals (k-I) of related phase.

5.14 Display of Reactive Power (VAR) Value

When RG3-T is in Automatic Mode (AUTO/MAN light is ON), VAR light is selected by means of DOWN button and system's Reactive Power value of phase L1 is displayed and you can select the measuring phase by pressing UP button. When ~1 2 3 lights are ON, total reactive power (ΣVAR) is displayed. This option is disabled in Manual Mode.

5.15 Display of Apparent Power (VA) Value

When RG3-T is in Automatic Mode (AUTO/MAN light is continuously ON), VA light is selected by means of DOWN button and system's Apparent Power value of phase L1 is displayed and you can select the measuring phase by pressing UP button. When ~1 2 3 lights are ON, total apparent power (ΣVA) is displayed. This option is disabled in Manual Operating Mode.

6. DESCRIPTION

6.1 Errors and Warnings

The Alarm Relay is activated if the following "errors" occur.

6.1.1 Over Voltage

If the phase-neutral voltage of the L1 phase exceeds or equals to preset Over Voltage Value (between 240-275V), then RG3-T waits for 3 seconds. If there is still over voltage at the end of 3 seconds then, OVER VOLTAGE LED turns on. Depending on selection of Over Voltage Protection Function (Pls. refer to 5.9), RG3-T switches off all the capacitor steps or continues to compensation. Over Voltage error disappears, if set Over Voltage value decreases by 4VAC. In this case OVER VOLTAGE LED turns off and RG3-T continues to compensation.

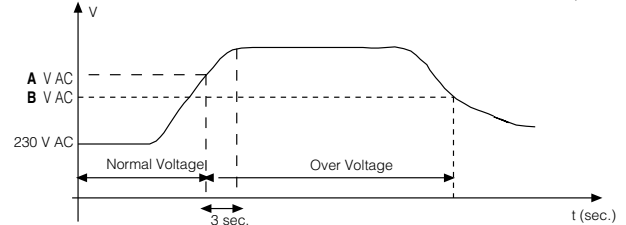

A: (Selected Over Voltage)
B: (Selected Over Voltage - 4 V AC)

6.1.2 Insufficient Compensation

When target power factor is not reached although all the capacitors have been connected, INSUFFICIENT COMPENSATION's light is ON and the Alarm Relay is activated.

6.1.3 Over Compensation

If the system is still capacitive although all the capacitors are disconnected, OVER COMPENSATION light is ON and Alarm Relay is activated.

6.2 Target Cosφ

The target Cosφ value can be adjusted between 0.85-1.00 inductive. RG3-T connects capacitors in order to bring system's power factor to the set value. The set value is defined as 1.25xQC₁ value. Switching operation occurs out of this region.

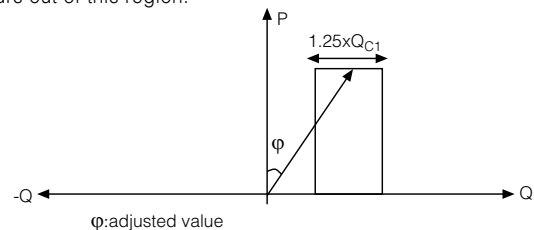

RG3-T calculates the average Cosφ value comparing it with the compensation set value and Power Factor (PF) value as described below.

Example :

Q: Reactive Power (VAR)
P: Active Power (W)
S: Apparent Power (VA)

$I_{L1}=5A$	$I_{L2}=4.5 A$	$I_{L3}=4A$
$V_{L1}=220 VAC$	$V_{L2}=215 VAC$	$V_{L3}=210 VAC$
$\text{Cos}\phi_{L1}=0.95$ (ind.)	$\text{Cos}\phi_{L2}=0.92$ (ind.)	$\text{Cos}\phi_{L3}=0.9$ (cap.)
$P_{L1}=V_{L1} \times I_{L1} \times \text{Cos}\phi_{L1} = 1045 W$	$P_{L2}=V_{L2} \times I_{L2} \times \text{Cos}\phi_{L2} = 890 W$	$P_{L3}=V_{L3} \times I_{L3} \times \text{Cos}\phi_{L3} = 504 W$
$Q_{L1}=V_{L1} \times I_{L1} \times \text{Sin}\phi_{L1} = 343.5 VAR$	$Q_{L2}=V_{L2} \times I_{L2} \times \text{Sin}\phi_{L2} = 379 VAR$	$Q_{L3}=V_{L3} \times I_{L3} \times \text{Sin}\phi_{L3} = 363 VAR$
$S_{L1}=V_{L1} \times I_{L1} = 1100 VA$	$S_{L2}=V_{L2} \times I_{L2} = 967.5 VA$	$S_{L3}=V_{L3} \times I_{L3} = 840 VA$

$$\text{Cos}\phi_{av} = \frac{\Sigma P}{\sqrt{(\Sigma Q)^2 + (\Sigma P)^2}} = 0.9895 \quad \text{Power Factor (PF)} = \frac{\Sigma P}{\Sigma S} = 0.8388$$

6.3 Adjustable Step Switching Time

Step switching on/off delay time can be adjusted between 2 sec.-1800 sec.

Warning: Shorter time than above can lead damage in capacitors and conductors.

If capacitor banks have not discharge coils, the delay time must be selected over 14 seconds. The selected delay time must not be shorter than the manufacturer's instruction.

6.4 Switching Program Selection

RG3-T has 5 different program modes which determines the power ratio sequence of the capacitor steps:

- PS1 selection ==> 1: 1: 1:.....: 1
- PS2 selection ==> 1: 2: 2:.....: 2
- PS3 selection ==> 1: 2: 4:.....: 4
- PS4 selection ==> 1: 2: 4: 8:.....: 8
- PS5 selection ==> may be all of the aboves

POWER FACTOR CONTROLLER RG3-T

6.4.1 RG3-T Capacitor Sequence Examples

The ratio between capacitor steps is very important. When choosing the ratio between capacitor steps, the rating of each capacitor step value may exceed that of the first by a maximum amount equal to the total of the preceding capacitor steps value. So the first step value will be the smallest one and the following steps must be the multiples of the first step.

Example: If the first capacitor power is 5 kVar, the capacitor power sequence of the following capacitors are as followed:

PS1 selection ==> 5, 5: 5:.....: 5
 PS2 selection ==> 5: 10: 10:.....: 10
 PS3 selection ==> 5: 10: 20:.....: 20
 PS4 selection ==> 5: 10: 20: 40:.....: 40
 PS5selection ==> may be all of the above

Two different switching program is supported by RG3-T :

- a) Rotational Switching : This switching program is rotational between equal steps in the clockwise direction and this switching program is rotational to ensure that the capacitor switching cycles are uniformly distributed over all steps and to provide minimum switching steps for maximum service life time of the system.
There are 4 different rotational switching program options.(PS1,PS2,PS3,PS4)
- b) Linear Operation : The switching program begins always from the first step to the last one in both switching on and off mode.The advantage of this switching program is the possibility of a large selection of capacitor steps conform to the step function ratio rule as explained above.The maximum possible ratio is "x:2x:4x:8x:16x....".
This switching program is selected by PS5 option.

6.5 Step Number Selection

By selecting the step number, (the quantity of steps which are in use), compensation system will be more effective and efficient. If step number is not selected, RG3-T makes the compensation according to the factory set step number which is max. available output as defined on the front panel.

6.6 C/k Setting

The C/k value is a threshold value for switching on/off the capacitor steps. C/k is the value obtained by dividing first step capacitor power "C" to the Current Transformer Ratio "k". This value is measured and calculated by RG3-T automatically, or this value can be entered manually.After pressing the UP and DOWN buttons together, the C/k value is calculated and stored in one step switching on/off time interval.The further compensation controls are made with this stored value. In case of instantaneous change of the system's load ,measuring process will be renewed. RG3-T will stop the measuring after 10 attempt.It means that the C/k value couldn't be measured due to the instability of the system's load.In this case compensation control will continue with the pre-stored value in the memory.

The formula to calculate the C/k value is :

$$C/k = \frac{Q}{k} \quad \begin{matrix} Q: \text{Power of the first step capacitor (kVar)} \\ k: \text{Current Transformer Ratio.(CTR)} \end{matrix}$$

Example :

Let the power (C) of the first step capacitor is 5 kVar and the Current Transformer Ratio (k) is 100/5.Then the C/k value is:

$$C/k = 5/(100/5)=0.25$$

C/k value for the different C and k values are as followed :

CTR (k)	Power of Capacitor Step (kVar)											
	2.5	5	10	12.5	15	20	25	30	40	50	60	100
30/5	0.42	0.83										
50/5	0.25	0.50	1.00									
75/5	0.17	0.33	0.67	0.83	1.00							
100/5	0.13	0.25	0.50	0.63	0.75	1.00						
150/5	0.08	0.17	0.33	0.42	0.50	0.67	0.83	1.00				
200/5	0.06	0.13	0.25	0.31	0.38	0.50	0.63	0.75	1.00			
300/5	0.04	0.08	0.17	0.21	0.25	0.33	0.42	0.50	0.67	0.83	1.00	
400/5	0.03	0.06	0.13	0.16	0.19	0.25	0.31	0.38	0.50	0.63	0.75	
500/5		0.05	0.10	0.13	0.15	0.20	0.25	0.30	0.40	0.50	0.60	1.00
600/5			0.08	0.10	0.13	0.17	0.21	0.25	0.33	0.42	0.50	0.83
800/5			0.06	0.08	0.09	0.13	0.16	0.19	0.25	0.31	0.38	0.63
1000/5			0.05	0.06	0.08	0.10	0.13	0.15	0.20	0.25	0.30	0.50
1250/5				0.05	0.06	0.08	0.10	0.12	0.16	0.20	0.24	0.40
1500/5					0.05	0.07	0.08	0.10	0.13	0.17	0.20	0.33
2000/5						0.05	0.06	0.08	0.10	0.13	0.15	0.25
2500/5							0.05	0.06	0.08	0.10	0.12	0.20
3000/5								0.05	0.07	0.08	0.10	0.17
4000/5									0.05	0.06	0.08	0.13

6.7 Current Transformer (CT) Selection

Always a separate CT must be used for the Power Factor Controller.The wires connecting CT to Power Factor Controller must be as short as possible and the diameter of wire not less than 1.5 mm. Since the current information is supplied by CT, the right selection of CT is very important. The secondary current of the selected CT must comply with the following current limits for correct measuring.
 Minimum=50 mA ,Maximum=5.5 A (Minimum C/k Ratio must be 0.02)

7. ERROR DESCRIPTIONS

7.1 Wrong Cosφ

Current and Voltage phase connections are not correct.

7.2 Insufficient Compensation

The capacitance of the capacitors may decrease by time. The fuses of the capacitors may have been out of order. The power of the selected capacitor steps may have been insufficient to compensate the system.(In this case user must increase the capacitor power.)

7.3 Over Compensation

This occurs (especially at weekends ,nights etc.) due to capacitive load current drawn by devices like ballasts,constant steps,etc. The contactor's contacts switching the capacitor steps may have stuck to each other due to the instantaneous over current.Unnecessary capacitor steps may have switched on manually.

7.4 Over Voltage

The phase-neutral voltage of L1 has exceeded the preset Over Voltage Value.

8. EASY INSTALLATION RECOMMENDATION (IMPORTANT NOTICE)

When the load is unstable and varies very quickly ,the C/k calculation process may take long time or in some cases it can not be calculated properly or miscalculated which may cause improper compensation. A practical way to prevent this situation is as followed:

1- Turn on the compensation board without connecting the load current.Only the capacitors will be in operation in this situation.(You can do this by switching off the load current temporarily)

2- Start the C/k calculation process by pressing the UP and DOWN buttons at the same time.

Now , depending on the power of the first step ,C/k value is calculated very accurately by RG3-T.

The calculated C/k value will automatically be stored in the memory.You can switch the load on.

This C/k value will be kept in the memory until it is recalculated or changed manually.

9. TECHNICAL SPECIFICATIONS

Rated Voltage (Un)	: 3x220 VAC,3x230 VAC, 3x240 VAC (Phase-Neutral Connection)
Operating Voltage Range (ΔU)	: (0.9-1.1)xUn
Operating Current Range (ΔI)	: 50mA-5.5A
Rated Frequency (f)	: 50 Hz / 60 Hz
Measuring Class	: 1% ± 1digit (V,I,cosφ), 2% ± 1digit(W,VAR,VA)
Power Consumption	: Current: <2 VA x 3 Voltage: 3 - 10 VA
Output Contact (↔)	: 3 A ,750 VA (NO Contact)
No-Volt Feature	: In case of power failure longer than 200 msec.all capacitor steps are disconnected automatically.
Setting Range	: Manual C/k Setting:0.02-1.00 Cosφ Setting:0.85 (ind.)-1.00 CT Ratio:5-10000
Time Delay	: Between 2 sec.-1800 sec.
Over Voltage Values	: 240-275 V AC (Selectable)
Factory Set Values	: Cosφ=1.00(ind.) , Step Time=7sec. Program=PS5 , C/k=0.05 CT Ratio=5
Number of Steps	: RG3-12T(max 12) ; RG3-8T(max 8) RG3-6T(max 6) ; RG3-5T(max 5)
Ambient Temperature	: -5°C - 55°C
Display	: 4 Digit ,Red Display
Equipment Protection Class	: Double Insulation-Class II (□)
Wire Section (For Terminal Block)	: 2.5 mm ²
Terminal Block Protection Class	: IP 00
Protection Class	: IP 20
Connections	: Socket terminals with screw
Dimension	: Type PR16
Switchboard cut-out	: 139x139 mm
Weight	: 0.8 kg.

10. DIMENSION

